

TECHNOLOGY MEETS QUALITY

Takeuchi proactively responds to our customers needs through world class product design, research and development, manufacturing and after the sale product support. Welcome to the next generation of Takeuchi Excavators.

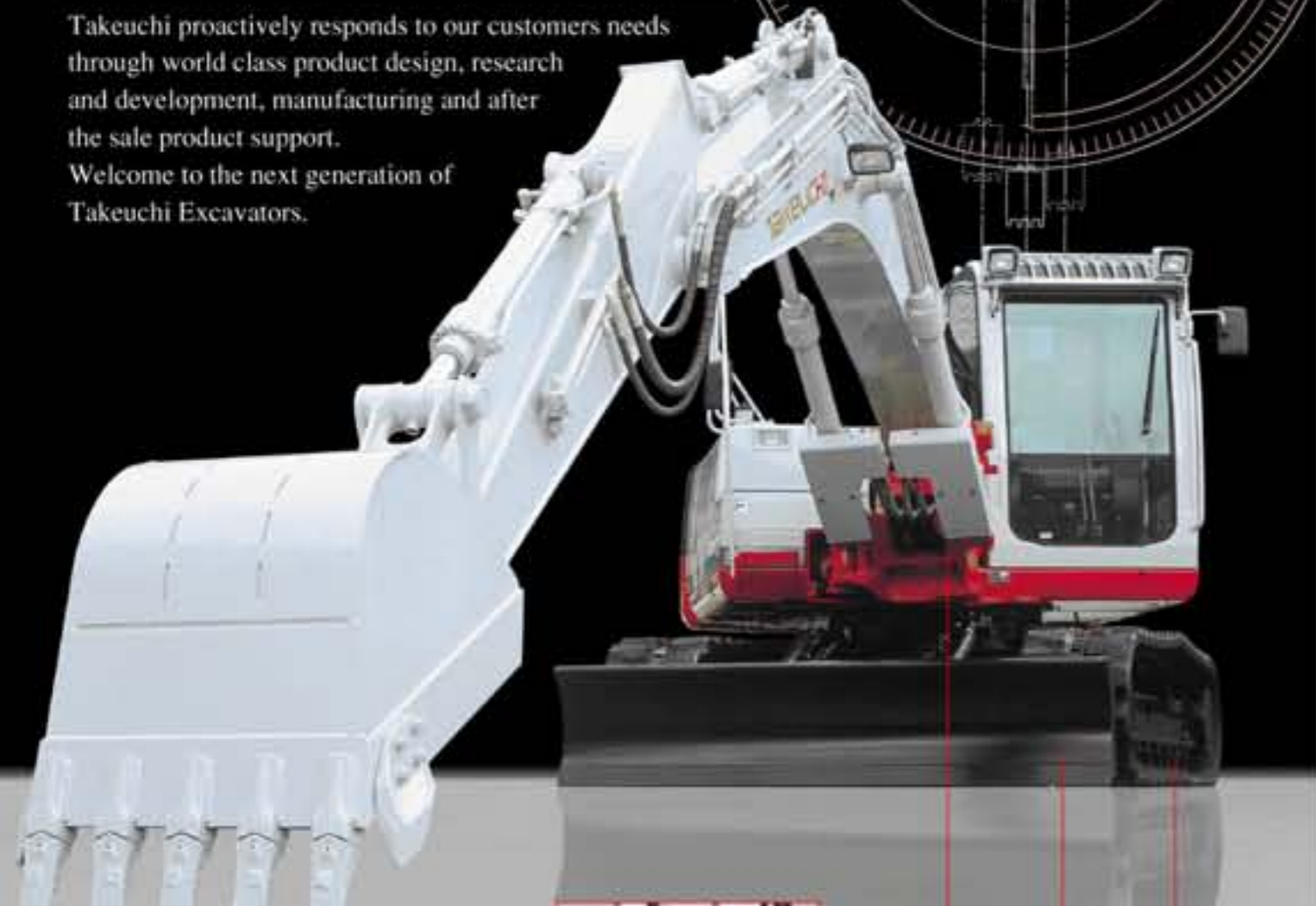

PRINCIPLE FEATURES of the TB1140



Boom Swing
for digging side ditches



Dozer Blade
for ground leveling



Rubber Tracks
for comfortable operating

TAKEUCHI

OPERATING RANGE : mm

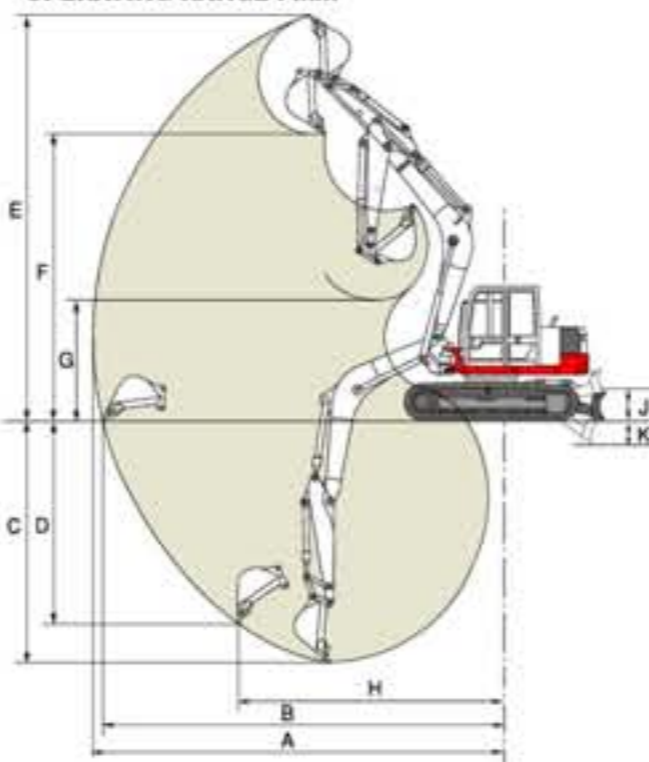

DIMENSION : mm

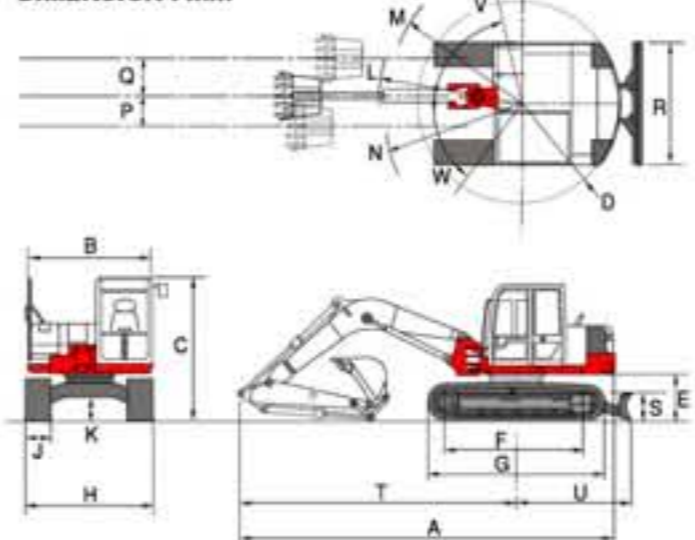

Item	Standard Arm		Long arm	
	Rubber Crawlers	Steel Crawlers	Rubber Crawlers	Steel Crawlers
A Max Digging Radius	8280	8755	8755	8755
B Max Floor Digging Radius	8080	8570	8570	8570
C Max Digging Depth	4990	5000	5490	5500
D Max Vertical Digging Depth	4145	4150	4630	4635
E Max Digging Height	8305	8300	8665	8660
F Max Dumping Height	5855	5850	6215	6210
G Min Dumping Height	2335	2330	1850	1845
H Max Vertical Digging Radius	5240	5355	5355	5355
J Max Raising Height	510	500	510	500
K Max Lowering Depth	490	500	490	500

Units:mm

A	7725	M	2255
B	2460	N	2665
C	2785	P	625
D	2000	Q	760
E	920	R	2490
F	2880	S	550
G	3590	T	5725
H	2490	U	2340
J	500	V	77
K	450	W	53
L	2855		

SPECIFICATIONS TB1140 (Cab, Rubber Tracked, Standard Arm, Breaker Piping Standard, Fops Cabin) (Steel Tracked: Option)

WEIGHT	Machine Weight	kg	14230	Rear Slew Radius	2000	OPERATING RANGE : mm	Max. Dig Depth	4990
BUCKET	Bucket Capa.	m ³	0.34(Struck)/ 0.45 (Heaped)	Min. Ground Clearance	450		Max. Vertical Dig Depth	4145
	Bucket Width	mm	970	PERFORMANCE			Max. Dump Height	5855
DIESEL ENGINE (Water-Cooled)	Model	ISUZU BB-4BG1TRE		Traction Speed	km/h	3.0/5.3	Max. Dig Height	8305
	Type	4CYL. 4CYCL		Upper Slew Speed	rpm	13.8	Max. Dig Radius	8280
	Rated Output	kW	62.2/2550rpm	Gradability	deg	35	Max. Floor Dig Radius	8080
	Max. Torque	Nm	304	Max Dig Power Bucket	kN	98.7	Min. Slew Radius	2255
	Displacement	cc	4329	Max Dig Power Arm	kN	64.9	Max. Bucket Offset RHLH	760-825
	Cool Water Capa.	lit	21	Ground Press	kPa	41.7	HYDRAULIC SYSTEM	
	Lub. Oil Capa.	lit	15.8(MAX)	DOZER BLADE : mm			Pump type	Variable (P1+P2) +Gear (P3+P4)
	Fuel Tank Capa.	lit	233	Width x Height	550X2490		Set Press	34.3+2+23.6+3.9
OVERALL DIMENSION:mm				Operating Range up/down	510/490		Discharge	106.6+2+51.9+20.5
Length (in transport)	7725			OFF-SET DIG FUNCTION			Breaker & Service Port	106.6
Width	2490			Type	Boom Swing		Slew Motor	Axial Piston
Height	2785			Swing Angle RHLH	53/77		Traction Motor	Axial Piston
				TRACTION SYSTEM : mm			Hydraulic Tank Capa.	95
				Crawler (Track)	Rubber / Steel			
				Track Width RT (ST)	500(500)			

WORLD CREATOR OF COMPACT EXCAVATOR
TAKEUCHI MFG.CO.,LTD.

205-3,Uwadaira,Sakaki-machi, Hanasima-gun.
Nagano 389-0605,Japan
Phone (81)268-81-1112
Telefax (81)268-81-1121
URL <http://www.takeuchi-mfg.co.jp>
E-mail marketing@takeuchi-mfg.co.jp



In accordance with our established policy of constant improvement, we reserve the right to amend this specification at any time without notice. Printed in Japan. TK 040250

FULL HYDRAULIC EXCAVATOR TB1140

Machine Weight : 14230 kg



TAKEUCHI

TAKEUCHI

Operator Comfort



ISOLATION MOUNTED CAB
minimizes noise levels and vibration within the operators station for added operator comfort and awareness of the excavators operating and worksite condition.



MULTI-ADJUSTABLE SUSPENSION SEAT
provides for long days of productive operation with minimal operator fatigue.

SHORT PITCH RUBBER TRACKS
provide vibration free travel even on the roughest ground condition.

HEAT/AIR CONDITIONER
provides a comfortable operating environment in all climates.



Safety

EMERGENCY ENGINE SHUT DOWN/RETURN TO IDLE SYSTEM
helps protect the engine from problems due to low oil pressure or high coolant temperature.

REAR MOUNTED WORK LIGHTS
improve job site safety by visually alerting anyone entering the excavators swing area.

CAST IRON, WRAP AROUND PROTECTIVE COUNTERWEIGHT
protects the engine compartment from accidental damage when working in confined areas.

SPRING-APPLIED, HYDRAULICALLY RELEASED
disk type parking brakes are installed on travel and slew motors for safe and reliable braking performance.



PROTECTIVE ROUTING OF BUCKET AND ARM CYLINDER HOSES
through the boom bracket virtually eliminates hose abrasion from narrow trench walls and excavation debris. In addition, the hose routing provides an unobstructed view to the work area.



CONSOLE SAFETY LOCKOUT LEVERS
disable travel and operating controls for safe entry and exit from the excavator.



RETRACTABLE SEAT BELT
is designed for comfort, convenience and encouragement for operator use of this important safety feature.

SIDE LIGHT
helps illuminate dark work areas.

Ease of Operation



HYDRAULIC ATTACHMENTS
are operated by momentary push button or proportionally controlled by the slider switch on the joystick.



ONE TOUCH ENGINE DECELERATOR
installed on the right hand joystick reduces fuel consumption when the excavator is temporary idled.



ENGINE SPEED
is easily set by feather touch button.

TWO-SPEED TRAVEL SHIFT-DOWN SYSTEM
automatically shifts travel speed from high to low speed when ground conditions call for additional traction power, ease of operation.

BOOM SWING is operated by pedal.

TRAVEL MOTORS
are equipped with shock less valves for smooth starts and stops.

Serviceability



THE FUEL SYSTEM AUTOMATICALLY BLEEDS AIR
from fuel lines on a fuel-depleted machine saving on time, tools and unnecessary service calls.

HYDRAULIC TEST PORTS
are conveniently located for ease of hydraulic system diagnostic testing.

GREASE GUN STORAGE
helps ensure that proper daily maintenance is performed.



NEW SERIES ENGINE
is designed to meet the most stringent worldwide exhaust emission standards and also provides significantly reduced noise levels for minimal disturbance in urban areas.



FULL OPENING REAR ENGINE COMPARTMENT
allows daily machine servicing to be conveniently accomplished from ground level.

Options

TKB801 HYDRAULIC BREAKER
is matched to the excavators hydraulic flow, pressure and operating capacity, enabling the excavator to efficiently perform concrete breaking and demolition work.

2nd AND 3rd AUXILIARY HYDRAULIC SERVICE PORT
powers attachments that require multiple hydraulic actuation.

QUICK CHANGE CONTROL PATTERN SELECTOR VALVE
enables operators to quickly choose the operating pattern with which they are most familiar.

OPTIONAL LONG ARM
increases the excavators working range.

FUEL TRANSFER PUMP
provides for easier machine refueling.

IMMOBILIZER SYSTEM
protects the machine from theft by requiring an ID coded key to start the excavator.

AUXILIARY POWER SOURCE
on the top of cabin allows for easy attachment of a rotating beacon light.

AIR SUSPENSION SEAT
provides additional operator comfort through an air support system.

